

VALCO 4259

| |
|----------------|
| PROJECT PROJET |
| SPEC TYPE |
| NOTES |



FINISH FINI



ANTE



WHE

FAMILY FAMILLE



4257

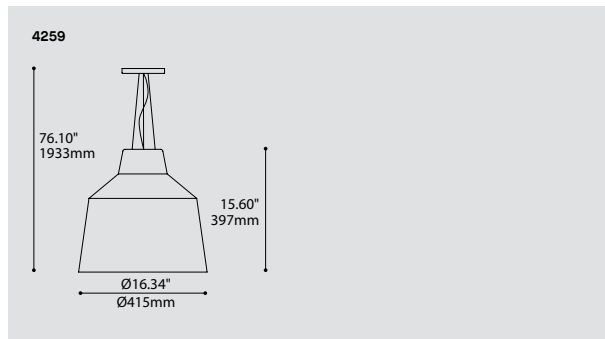

| ORDERING SPECIFICATION | SPÉCIFICATION DE COMMANDE | CODE |
|--|--|--------|
| MODEL MODÈLE | | 4259 |
| 4259 | VALCO | |
| LIGHT SOURCE SOURCE LUMINEUSE | | LED.24 |
| LED.24 | 24W, LED | |
| COLOR TEMPERATURE TEMPÉRATURE DE COULEUR | | |
| 27* | 2700K | |
| 30 | 3000K | |
| 35 | 3500K | |
| 40 | 4000K | |
| | * LONGER LEAD TIME MAY APPLY, PLEASE CONTACT YOUR EUREKA REPRESENTATIVE | |
| COLOR RENDERING INDEX (CRI) INDICE DE RENDU DE COULEUR (IRC) | | |
| 80 | 80+ CRI | |
| 90* | 90+ CRI | |
| | * LONGER LEAD TIME MAY APPLY, PLEASE CONTACT YOUR EUREKA REPRESENTATIVE | |
| VOLTAGE VOLTAGE | | |
| 120V | 120 VOLT | |
| 277V | 277 VOLT | |
| CONTROL OPTION OPTION DE CONTRÔLE | | |
| DV | 0-10V DIMMING (120V-277V) | |
| DP | PHASE DIMMING (120V ONLY) | |
| NLTAIR2* | NLIGHT AIR CONTROL GEN 2 | |
| NLIGHT* | NLIGHT WIRED CONTROL | |
| | *REQUIRES RC2 CANOPY * EMERGENCY BATTERY NOT AVAILABLE WITH NLIGHT OPTIONS REFER TO NLIGHT GUIDE AND INSTALLATION SHEET FOR ALL REQUIREMENTS. | |
| EMERGENCY BATTERY BATTERIE D'URGENCE | | |
| | AVAILABLE WITH LED SOURCES 120-227V. EM DRIVER BOX INCLUDED, INSTALLED REMOTELY. SEE EM GUIDE FOR DETAILS. WITH DV DIMMING OPTION, AN ADDITIONAL POWER CABLE WILL DROP FROM CEILING NEXT TO MAIN CABLE. | |
| EMB* | EMERGENCY BATTERY FOR REMOTE BOX | |
| | *3981EA ACCESSORY IS REQUIRED | |
| CABLE CÂBLE | | AC |
| AC | AIR-CRAFT MOUNTING & CLEAR CABLE, FIELD ADJUSTABLE | |
| CABLE LENGTH LONGUEUR DE CÂBLE | | |
| 60 | 60" AIRCRAFT CABLE (STD LENGTH) | |
| ** | CUSTOM AIRCRAFT CABLE LENGTH (PLEASE SPECIFY) | |
| | FOR OVERALL LENGTH, PLEASE CONTACT YOUR EUREKA REPRESENTATIVE | |
| MOUNTING MONTAGE | | |
| RC1 | ROUND CANOPY / PAVILLON ROND | |
| RC2 | SCREWLESS 0.5" CANOPY (2471C) | |
| | NLIGHT SCREWLESS CANOPY Ø7.75" X 1.30" (2474H) | |
| CANOPY FINISH FINI PAVILLON | | |
| WHE | WHITE FINE TEXTURE | |
| ANTE | ANTHRACITE FINE TEXTURE | |
| SHADE FINISH FINI ABAT-JOUR | | |
| WHE | WHITE FINE TEXTURE | |
| ANTE | ANTHRACITE FINE TEXTURE | |
| ACCESSORY ACCESSOIRE | | |
| 3981EA | ELECTRICAL BOX FOR EMB EMERGENCY BATTERY | |

PRODUCT CHARACTERISTICS CARACTÉRISTIQUES DU PRODUIT



- DESIGN:** The minimalist silhouette distinguishes itself by its unique lines which gives it a contemporary tone. Suspended alone or in a group, Valco creates a soft and comfortable illumination throughout the room.
- INSTALLATION:** Easy to install, adjust and level triple aircraft cable mounting.
- LIGHT SOURCE:** 24W custom LED light engine supplied with a standard dimming driver (0-10V or phase).
- CANOPY:** Die-formed steel canopy with a machined aluminum diffuser support.
- SHADE:** Custom spun aluminum shade anthracite or white architectural grade fine texture finishes.
- CERTIFIED:** c-CSA-us

VALCO 4259

QUICKSHIP

PROJECT PROJET

SPEC TYPE

NOTES



FINISH FINI



ANTE



WHE

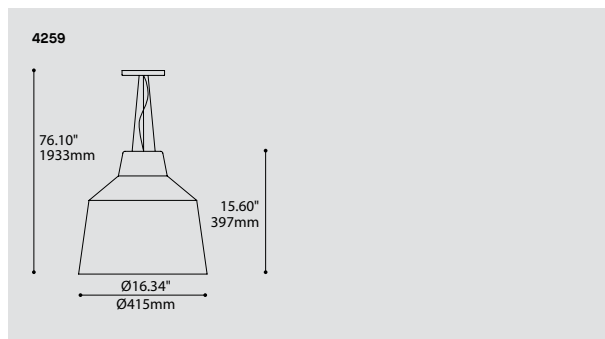

ORDERING SPECIFICATION SPÉCIFICATION DE COMMANDE

CODE

QUICKSHIP

QS5 QUICKSHIP 5 DAYS - MAXIMUM 5 UNITS QUICKSHIP 5 JOURS - MAXIMUM 5 UNITÉS
QS10 QUICKSHIP 10 DAYS - MAXIMUM 20 UNITS QUICKSHIP 10 JOURS - MAXIMUM 20 UNITÉS

MODEL MODÈLE

4259 VALCO

4259

LIGHT SOURCE SOURCE LUMINEUSE

LED.24 24W, LED

LED.24

COLOR TEMPERATURE TEMPÉRATURE DE COULEUR

30 3000K
35 3500K
40 4000K

COLOR RENDERING INDEX (CRI) INDICE DE RENDU DE COULEUR (IRC)

80 80+ CRI

80

VOLTAGE VOLTAGE

120V 120 VOLT
277V 277 VOLT

DIMMING OPTION OPTION DE GRADATION

DV 0-10V DIMMING (120V-277V)
DP PHASE DIMMING (120V ONLY)
LED DIMMING DRIVER IS STANDARD IN THIS PRODUCT, PLEASE SPECIFY YOUR DIMMING TYPE

CABLE CÂBLE

AC AIR-CRAFT MOUNTING & CLEAR CABLE, FIELD ADJUSTABLE

AC

CABLE LENGTH LONGUEUR DE CÂBLE

60 60" AIRCRAFT CABLE (STD LENGTH)
** CUSTOM AIRCRAFT CABLE LENGTH (PLEASE SPECIFY)
FOR OVERALL LENGTH, PLEASE CONTACT YOUR EUREKA REPRESENTATIVE

CANOPY FINISH FINI PAVILLON

WHE WHITE FINE TEXTURE

WHE

SHADE FINISH FINI ABAT-JOUR

WHE WHITE FINE TEXTURE
ANTE ANTHRACITE FINE TEXTURE

PRODUCT CHARACTERISTICS CARACTÉRISTIQUES DU PRODUIT

BIM DIM EMB IES LED

DESIGN:

The minimalist silhouette distinguishes itself by its unique lines which gives it a contemporary tone. Suspended alone or in a group, Valco creates a soft and comfortable illumination throughout the room.

INSTALLATION:

Easy to install, adjust and level triple aircraft cable mounting.

LIGHT SOURCE:

24W custom LED light engine supplied with a standard dimming driver (0-10V or phase).

CANOPY:

Die-formed steel canopy with a machined aluminum diffuser support.

SHADE:

Custom spun aluminum shade anthracite or white architectural grade fine texture finishes.

CERTIFIED:

c-CSA-us

CONCEPTION:

Ce luminaire à la silhouette épurée se distingue par ses arêtes prononcées qui lui donnent un ton actuel. Suspendu seul ou en groupe, il crée une douce illumination à travers la pièce.

INSTALLATION:

Câbles de retenue en acier facilitant l'installation, l'ajustement et la mise à niveau.

SOURCE LUMINEUSE:

Module lumineux DEL de 24W fait sur mesure et unité d'alimentation à intensité variable standard (0-10V ou phase).

PAVILLON:

Structure d'acier et support à diffuseur usiné en aluminium.

ABAT-JOUR:

Abat-jour en métal repoussé avec une peinture anthracite ou blanche finement texturée de grade architectural.

CERTIFIÉ:

c-CSA-us

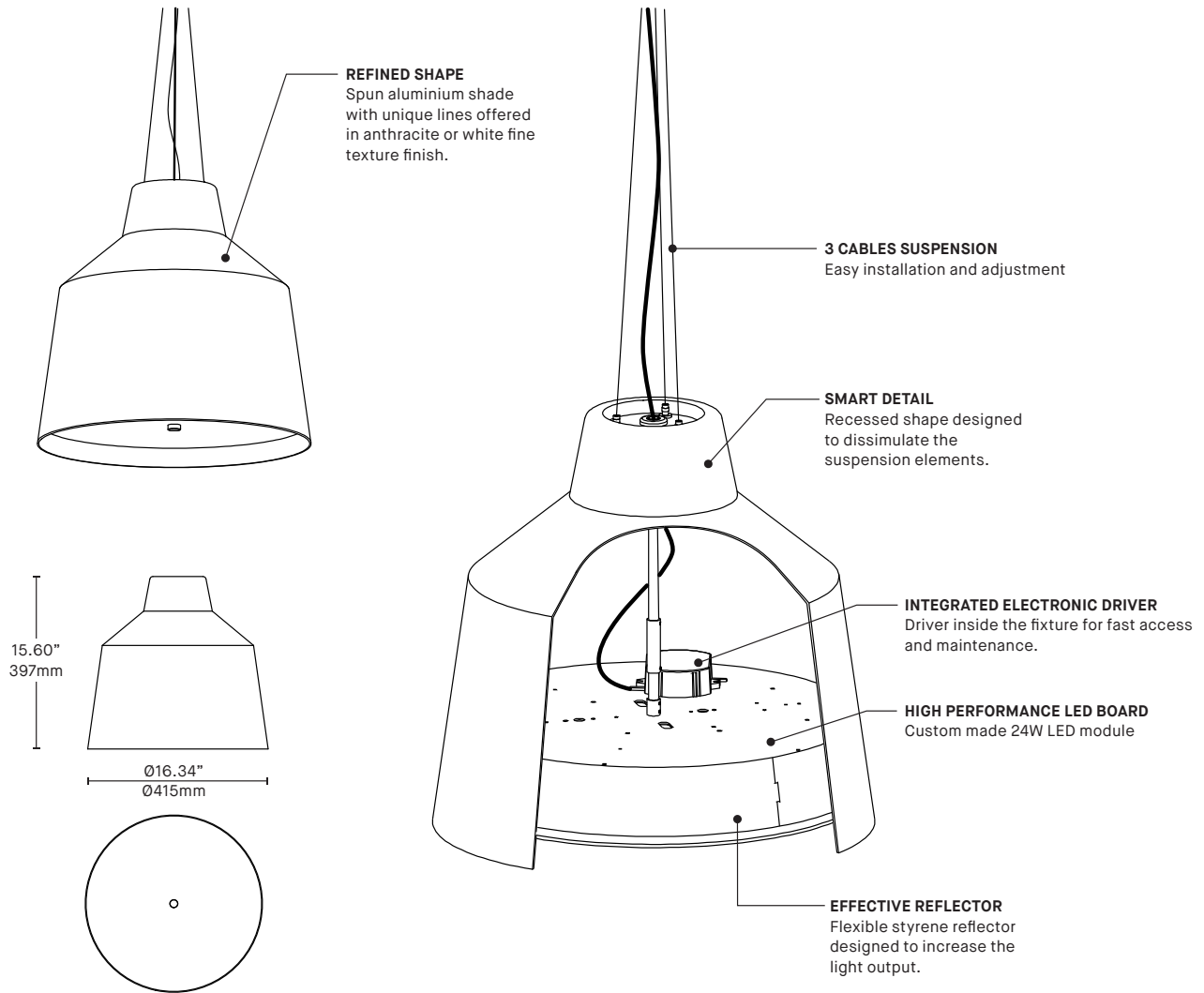

PRODUCT SPECIFICATION 4259

| PERFORMANCE | |
|-----------------------------------|---|
| SYSTEM WATTAGE | 30.7W |
| DELIVERED LUMENS (4000K) | 2820LM |
| EFFICACY | 91.9LM/W |
| OTHER INFORMATIONS | |
| LUMINAIRE'S WEIGHT | 8.50 LBS / 3.85KG |
| L70 (LUMEN MAINTENANCE) | > 60 000 HRS |
| WELL & LEED STANDARD REQUIREMENTS | |
| MAX. LUMINANCE 45°-90° OF NADIR | 2644 CD/M ² |
| LIGHT QUALITY | R9 > 50 (90 CRI OPTION) |
| FLICKERING TOLERANCE | LOW FLICKER, COMPLIANT TO CALIFORNIA TITLE 24 |

EFFICACY MULTIPLIERS

| CRI | CCT | FACTOR |
|-----|-------|--------|
| 80+ | 4000K | 1.00 |
| 80+ | 3500K | 0.98 |
| 80+ | 3000K | 0.94 |
| 80+ | 2700K | 0.91 |
| 90+ | 4000K | 0.88 |
| 90+ | 3500K | 0.85 |
| 90+ | 3000K | 0.81 |
| 90+ | 2700K | 0.77 |

LIGHT DISTRIBUTION

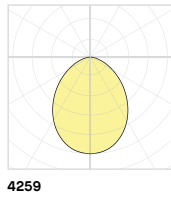

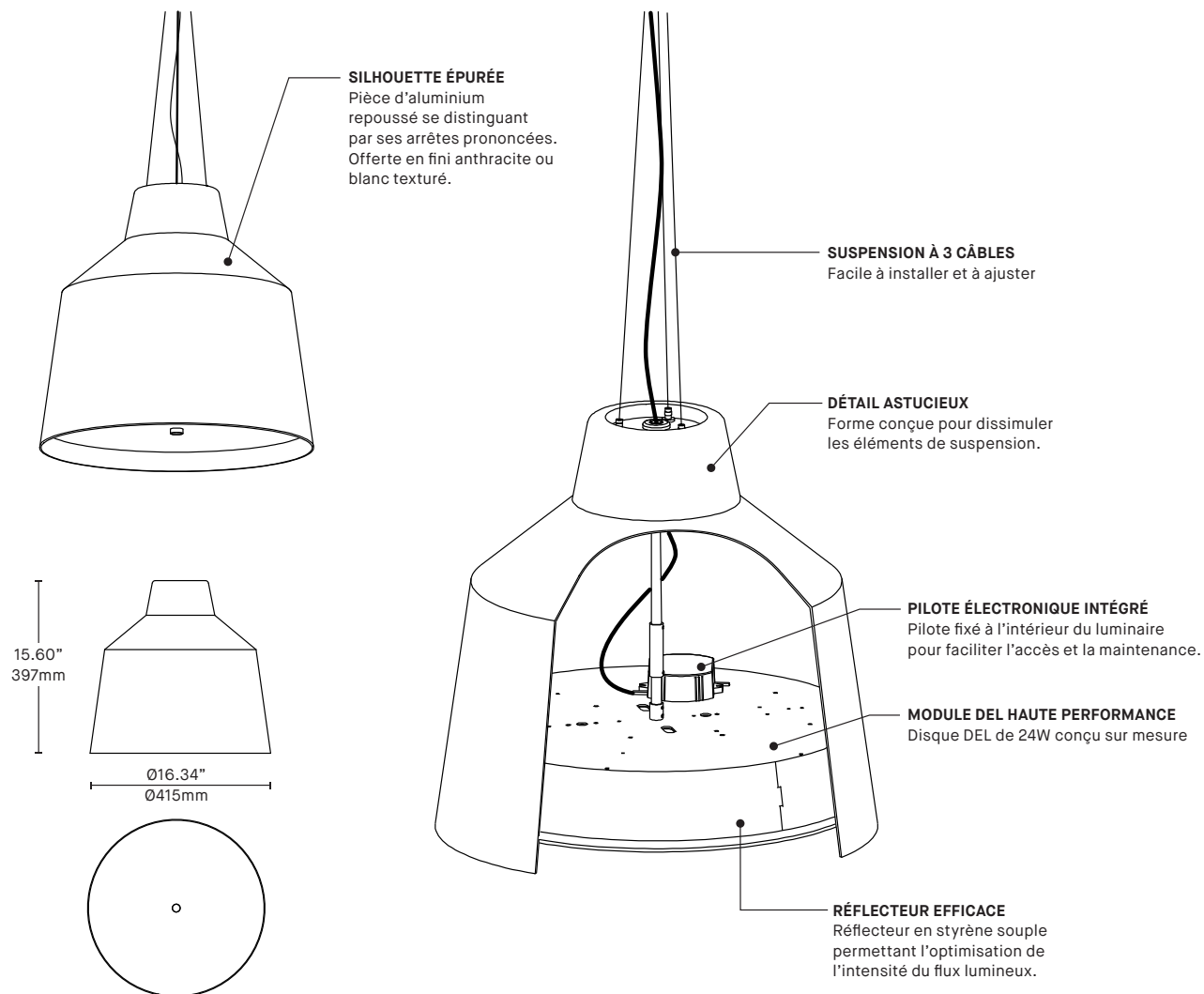

SPÉCIFICATION PRODUIT 4259

PERFORMANCE

| | |
|----------------------|----------|
| PUISSANCE TOTALE | 30.7W |
| LUMENS RÉELS (4000K) | 2820LM |
| EFFICACITÉ | 91.9LM/W |

AUTRES INFORMATIONS

| | |
|---------------------------------|-------------------|
| POIDS DU LUMINAIRE | 8,50 LBS / 3,85KG |
| L70 (MAINTENANCE DE LA LUMIÈRE) | > 60 000 H |

CRITÈRES DE CERTIFICATION WELL & LEED

| | |
|------------------------------|--|
| MAX. LUMINANCE 45°-90° NADIR | 2644 CD/M ² |
| QUALITÉ DE LA LUMIÈRE | R9 > 50 (OPTION 90 IRC) |
| TOLÉRANCE DE CLIGNOTEMENTS | PEU DE CLIGNOTEMENT (CONFORME À CALIFORNIA TITLE 24) |

FACTEUR D'EFFICACITÉ

| IRC | CCT | FACTEUR |
|-----|-------|---------|
| 80+ | 4000K | 1.00 |
| 80+ | 3500K | 0.98 |
| 80+ | 3000K | 0.94 |
| 80+ | 2700K | 0.91 |
| 90+ | 4000K | 0.88 |
| 90+ | 3500K | 0.85 |
| 90+ | 3000K | 0.81 |
| 90+ | 2700K | 0.77 |

DISTRIBUTION LUMINEUSE

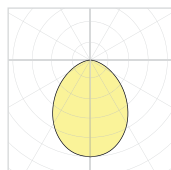

4259



Visitez notre site Web pour les termes et conditions.

JUNCTION BOX 3981E

| |
|----------------|
| PROJECT PROJET |
| SPEC TYPE |
| NOTES |



ORDERING SPECIFICATION SPÉCIFICATION DE COMMANDE

| MODEL MODÈLE | CODE |
|--------------|--|
| 3981EA | APPROX. 10W MAX EMERGENCY BACKUP POWER |
| 3981EB | APPROX. 5W MAX EMERGENCY BACKUP POWER |

PRODUCT CHARACTERISTICS CARACTÉRISTIQUES DU PRODUIT

- DESIGN:** Remote junction box and cover with an emergency backup driver. Features matching wires and labelling to simplify installation. Is required to complete luminaires ordered with EMB remote emergency box option (selected models, refer to specification sheets. Other models possible upon request). Available in several power outputs, selected according to the luminaire power.
- STRUCTURE:** Die-stamped 16 gauge grey painted steel. Knockouts on all 4 sides from 1/2" to 1-1/4".
- CERTIFIED:** c-CSA-us, UL, RoHS, NEMA Type 1, FCC
- CONCEPTION:** Boîte de jonction à distance avec couvercle avec batterie d'urgence intégré. Contient des fils avec couleurs et étiquetage pour simplifier l'installation. Requis pour compléter un luminaire commandée avec l'option EMB (voir pages de spécification pour produits avec l'option EMB. Autres produits possibles sur demande). Disponible en plusieurs puissances, sélectionnées en fonction du luminaire.
- STRUCTURE:** Acier plié de 16 jauge peinturé gris avec coins soudés. Débouchures sur 4 côtés 1/2" à 1-1/4".
- CERTIFIÉ:** c-CSA-us, UL, RoHS, NEMA Type 1, FCC

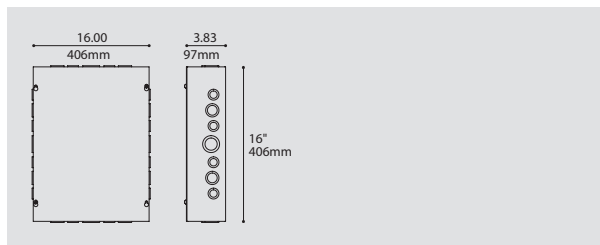

INSTALLATION SUMMARY SOMMAIRE D'INSTALLATION

STEP 1 ÉTAPE 1

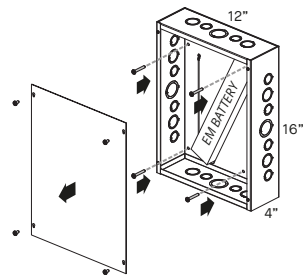

Remove cover and fasten box remotely to a wall or a ceiling.
Enlever le couvercle et fixer la boîte à distance sur un mur ou un plafond.

STEP 2 ÉTAPE 2

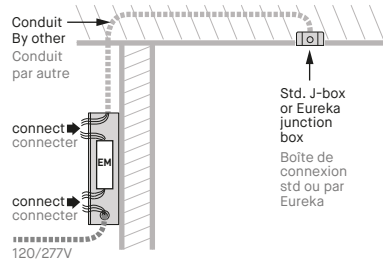

Run conduit from box to junction box of luminaire. Conduit must have a minimum of 5 wires with wire gauge and maximum distance as per EM driver distance chart. Connect EM driver to conduit wires and ac branch circuit. Faites passer le conduit de la boîte EM à la boîte de connexion du luminaire. Consulter le tableau de "distance maximale" disponible dans la feuille d'installation. Branchez la batterie EM avec les fils du conduit ainsi que la ligne 120V ou 277V.

STEP 3 ÉTAPE 3

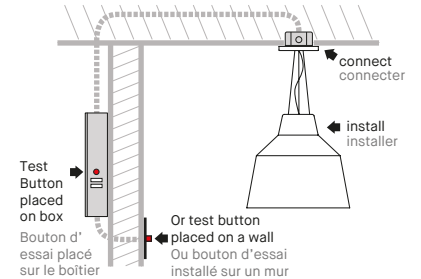

Install luminaire & connect its wires to conduit. Install test button on wall or box (wall plate not supplied). Installer le luminaire & connecter les fils au conduit. Installer le bouton d'essai sur le mur ou boîtier (plaque murale non fournie).

REFER ALSO TO INSTALLATION DRAWING AND EM GUIDE FOR MORE INFORMATION.
CONSULTEZ LE DESSIN D'INSTALLATION ET LE GUIDE EM POUR PLUS D'INFORMATIONS.



SPECIFICATION

3981E REMOTE EMERGENCY BOX KIT - IOTA EM DRIVER

SAFETY GUIDELINES :

- > Follow safety instructions and guidelines of EM battery/driver manufacturer for the specific model.
- > Install by qualified personnel in accordance with the National Electrical Code and local regulations.
- > Turn off power supply before installation or servicing the fixture.

EMB LOCATION :

- > The 3981E box connects to a luminaire ordered with an EMB option (which has specific EM WIRING).
- > Consult our chart for maximum remote distance of EM battery to luminaire leds.
- > Establish desired location for EMB box & EM test button on box or on a wall.

EM Remote Distance Chart
Maximum distance EM battery to Luminaire LEDs (Ft)

| MAX EM BOX DISTANCE (Ft) | CONDUIT WIRE GAUGE (AWG) | | | | | | | |
|--------------------------|--------------------------|-------|------|------|------|------|------|-----|
| | 10 | 12 | 14 | 16 | 18 | 20 | 22 | |
| LUMINAIRE | 200mA | 1043' | 651' | 413' | 259' | 163' | 103' | 65' |
| DRIVER | 350mA | 596' | 372' | 236' | 148' | 93' | 59' | 37' |
| OUTPUT | 500mA | 417' | 261' | 165' | 104' | 65' | 41' | 26' |
| CURRENT* | 700mA | 298' | 186' | 118' | 74' | 47' | 29' | 18' |
| (Amps) | 1000mA | 209' | 130' | 83' | 52' | 33' | 21' | 13' |
| *Contact Eureka | 1400mA | 149' | 93' | 59' | 37' | 23' | 15' | 9' |
| | 2000mA | 104' | 65' | 41' | 26' | 16' | 10' | 6' |
| | 3000mA | 70' | 43' | 28' | 17' | 11' | 7' | 4' |

EMB PLACEMENT EXAMPLES :

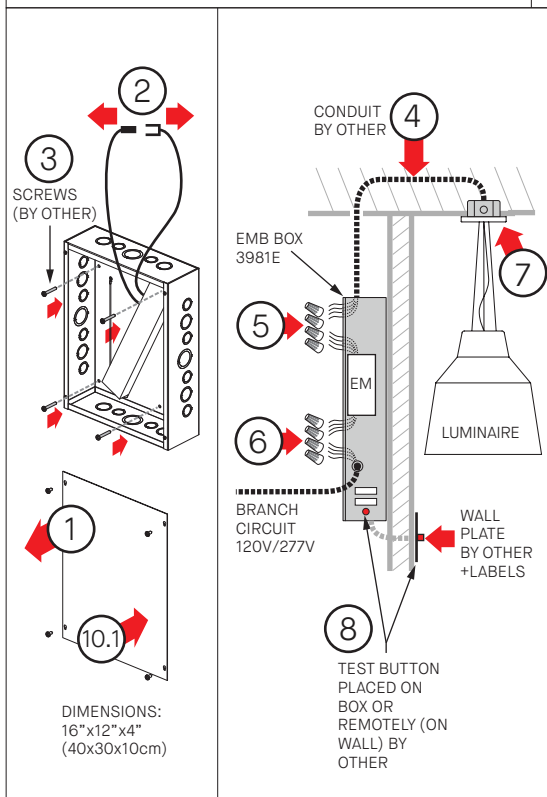
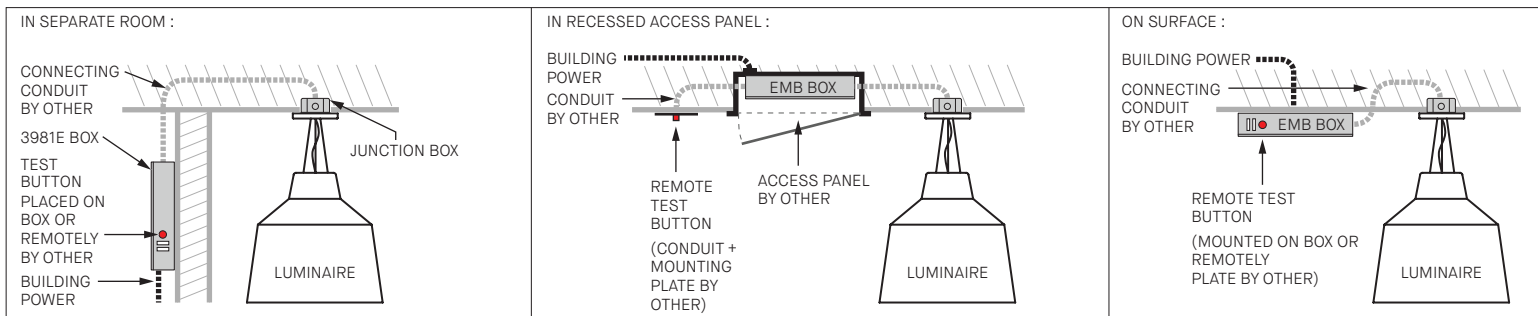

WIRING DIAGRAM:

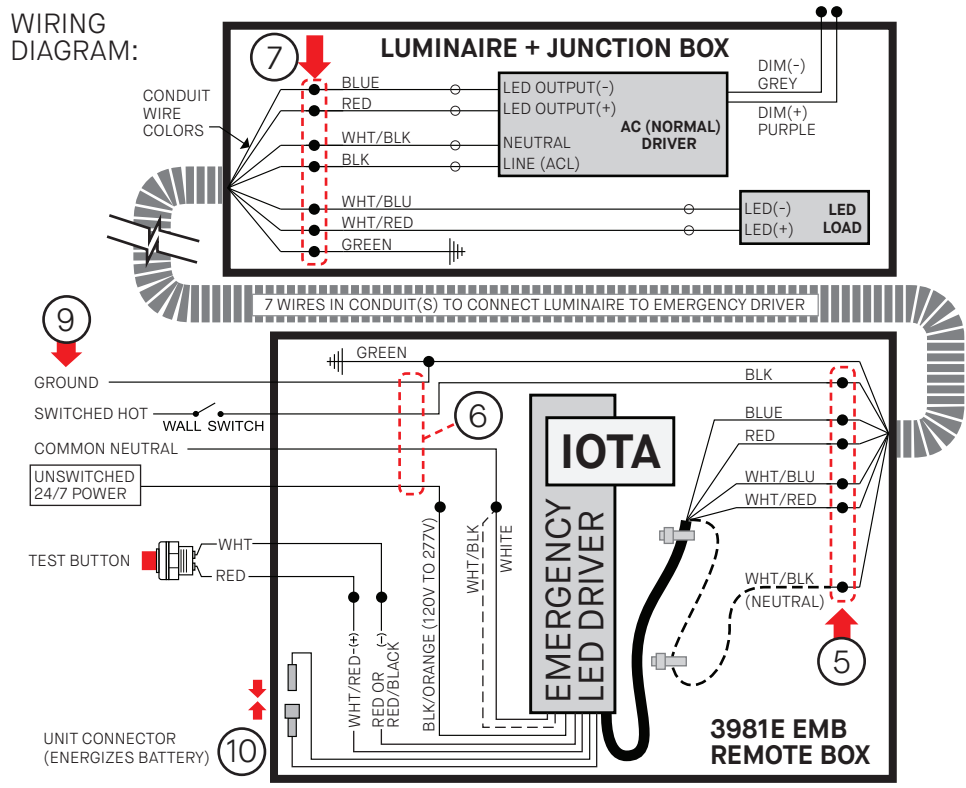

INSTALLATION

- 1 - REMOVE BOX COVER.
- 2 - IF CONNECTED, DISCONNECT THE EM BATTERY 'UNIT CONNECTOR' (WHITE).
- 3 - SCREW BOX TO MOUNTING SURFACE (SCREWS NOT SUPPLIED)
- 4 - RUN CONDUIT FROM EMB BOX TO ELECTRICAL JUNCTION BOX OF LUMINAIRE. CONDUIT MUST HAVE MIN. 7 WIRES AND WIRE GAUGE AS PER DISTANCE CHART.
- 5 - CONNECT CONDUIT WIRES TO EM BATTERY AS PER WIRING DIAGRAM.
CAREFULLY NOTE WHICH WIRE COLORS ARE CONNECTED TOGETHER ON EACH END.
- 6 - CONNECT BATTERY TO AC BRANCH CIRCUIT : GROUND, NEUTRAL, 24/7 UNSWITCHED LINE (HOT) AND SWITCHED LINE (ON SAME CIRCUIT AS LUMINAIRE ON/OFF CONTROL).
- 7 - INSTALL SPECIFIC EM LUMINAIRE, CONNECT WIRES TO CONDUIT USING THE SAME CORRESPONDING COLORS NOTED AT THE EM BATTERY-CONDUIT CONNECTION.
- 8 - INSTALL EM BATTERY TEST BUTTON IN DESIRED LOCATION. WALL PLATE BY OTHER. ADD LABELS "PUSH TO TEST" & CHARGING INDICATOR LIGHT".

- 9 - SWITCH ON AC POWER.
- 10 - JOIN THE EM BATTERY CONVERTOR CONNECTOR. 10.1 - INSTALL BOX COVER.
- 11 - IF EMB IS FAR FROM THE LUMINAIRE, IDENTIFY TO WHICH LUMINAIRE IT IS CONNECTED.

AT THIS POINT POWER SHOULD BE CONNECTED TO BOTH THE AC DRIVER AND THE EMERGENCY DRIVER & TEST/CHARGE LIGHT SHOULD ILLUMINATE, INDICATING BATTERY IS CHARGING.

TESTING & EM DRIVER/BATTERY MAINTENANCE:

CONDUCT A SHORT-TERM DISCHARGE TEST AFTER THE EMERGENCY DRIVER HAS BEEN CHARGED FOR MINIMUM ONE HOUR. CHARGE FOR 24 HOURS BEFORE CONDUCTING A LONG-TERM DISCHARGE TEST.

FOLLOW GUIDELINES FROM THE EM DRIVER/BATTERY MANUFACTURER INSTRUCTIONS FOR THE REQUIRED PERIODIC TESTING AND MAINTENANCE GUIDELINES.

3981E BOÎTE D'URGENCE À DISTANCE - DRIVER EM IOTA

DIRECTIVES DE SÉCURITÉ:

- > Suivre les consignes de sécurité et les directives d'installation du fabricant de la batterie d'urgence.
- > Installer par du personnel qualifié conformément au code électrique national et local.
- > Fermer l'alimentation avant l'installation ou l'entretien.

EMPLACEMENT :

- > Cette boîte 3981E se connecte à un luminaire commandé avec l'option EMB (qui a du filage spécifique).
- > Consulter le tableau pour la distance maximale de la batterie d'urgence aux DELs du luminaire.
- > Déterminer l'emplacement souhaité pour la boîte EMB et le bouton de test d'urgence.

EXEMPLES D'EMPLACEMENT:

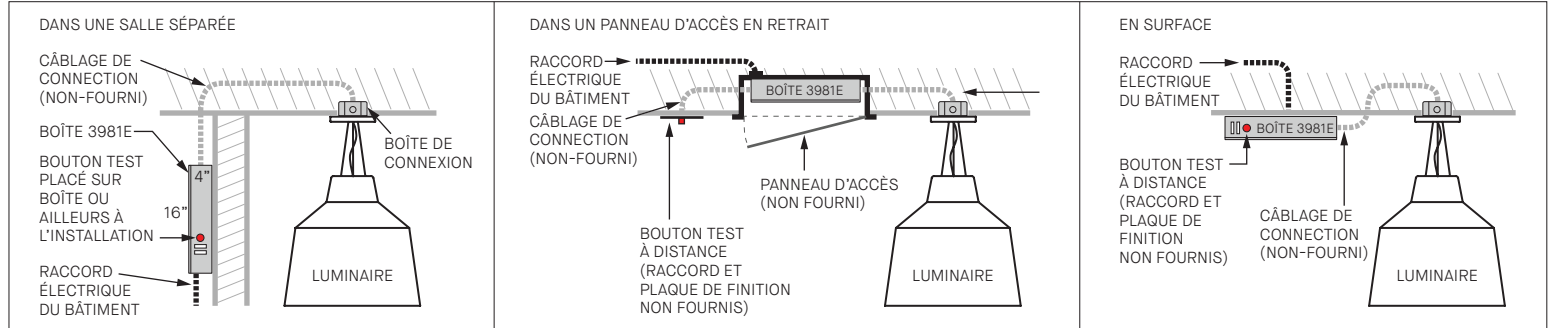

Charte de distance d'installation EM

Distance maximale entre Batterie d'urgence et DELs du luminaire (Pi)

| DISTANCE MAX D'INSTALLATION (Pi) | GAUGE DE FILS DU CONDUIT (AWG) | | | | | | | |
|----------------------------------|--------------------------------|-------|------|------|------|------|------|-----|
| | 10 | 12 | 14 | 16 | 18 | 20 | 22 | |
| COURANT | 200mA | 1043' | 651' | 413' | 259' | 163' | 103' | 65' |
| ALIMENTATION DU LUMINAIRE* | 350mA | 596' | 372' | 236' | 148' | 93' | 59' | 37' |
| 700mA | 417' | 261' | 165' | 104' | 65' | 41' | 26' | |
| 1000mA | 298' | 186' | 118' | 74' | 47' | 29' | 18' | |
| *Contacter Eureka | 1400mA | 209' | 130' | 83' | 52' | 33' | 21' | 13' |
| | 2000mA | 149' | 93' | 59' | 37' | 23' | 15' | 9' |
| | 3000mA | 104' | 65' | 41' | 26' | 16' | 10' | 6' |
| | | 70' | 43' | 28' | 17' | 11' | 7' | 4' |

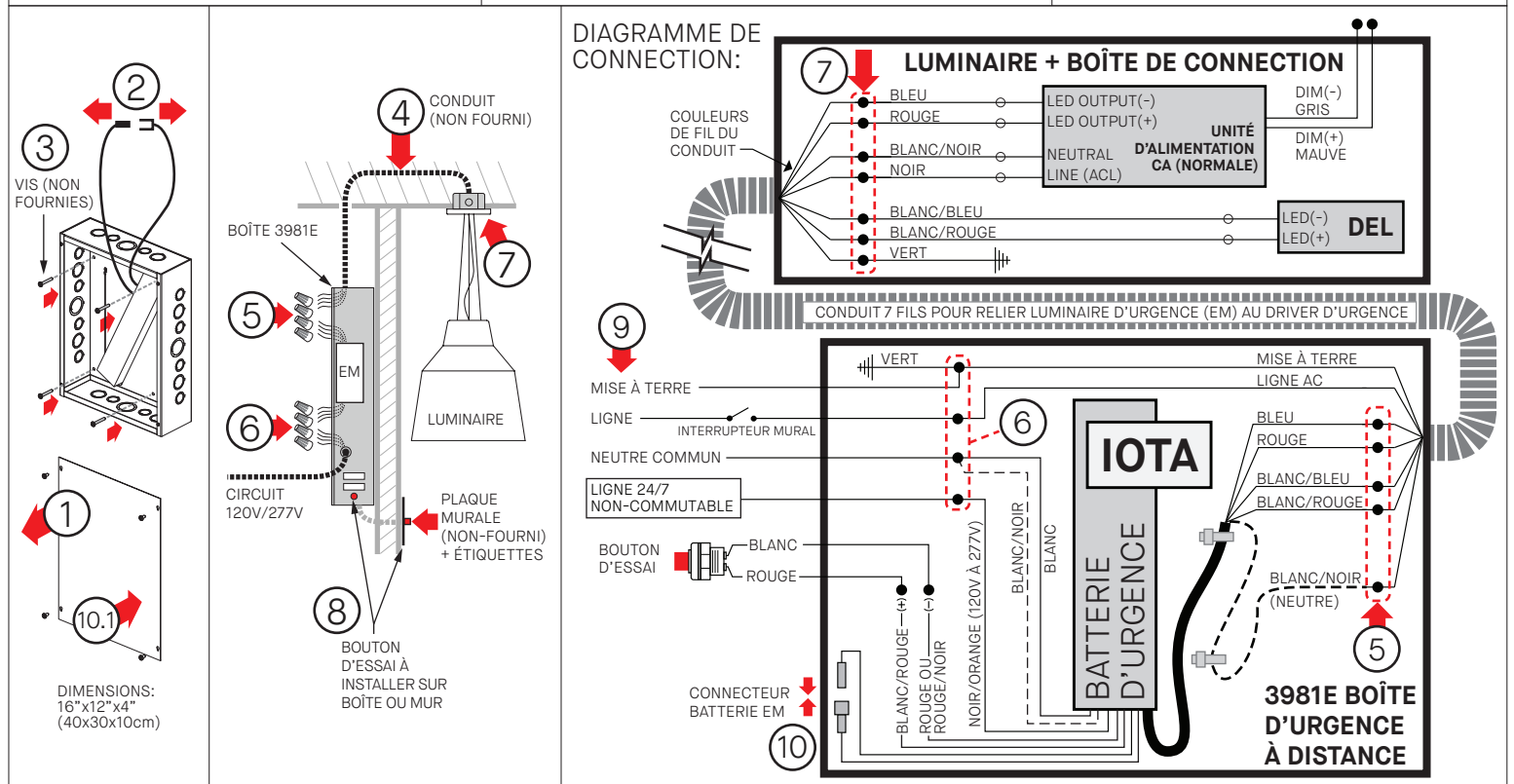

INSTALLATION

- 1 - DÉVISSER LE COUVERCLE.
- 2 - DÉCONNECTER LE CONNECTEUR BLANC DE BATTERIE EM (UNIT CONNECTOR).
- 3 - FIXER LA BOÎTE SUR LE MUR/PALAFOND AVEC VIS (NON FOURNIES)
- 4 - PASSER DU CONDUIT DU EMB VERS LA BOÎTE DE CONNEXION ÉLECTRIQUE DE LUMINAIRE. LE CONDUIT DOIT AVOIR 7 FILS AVEC GAUGE DE FIL SELON CHARTE DE DISTANCE.
- 5 - CONNECTER LES FILS DE CONDUIT À LA BATTERIE EM SELON LE SCHÉMA DE CÂBLAGE.
- 6 - CONNECTER LA BATTERIE AU CIRCUIT DE DÉRIVATION AC (FILS: MISE A LA TERRE, NEUTRE, LIGNE & LIGNE SANS INTERRUPTEUR 24H/7* (*DOIT ETRE LE MEME CIRCUIT QUE LE CONTROLE DU LUMINAIRE)).
- 7 - INSTALLER LUMINAIRE SPÉCIFIQUE EM, CONNECTER LES FILS AU CONDUIT AVEC MÊMES COULEURS CORRESPONDANTES DE LA BATTERIE EM AUX FILS DE CONDUIT.
- 8 - INSTALLEZ LE BOITON D'ESSAI DE BATTERIE EM DANS L'ENDROIT SOUHAITÉ (PLAQUE MURALE PAR AUTRE). COLLER ÉTIQUETTES "PUSH TO TEST" & CHARGING INDICATOR LIGHT".

- 9 - ALIMENTER LE CIRCUIT AC.
- 10 - JOINDRE CONNECTEUR BLANC DE BATTERIE EM. 10.1 - INSTALLER COUVERCLE DE BOITE.
- 11 - SI LE EMB EST LOIN DU LUMINAIRE, IDENTIFIER À QUEL LUMINAIRE IL EST CONNECTÉ.

A CE STADE, L'ALIMENTATION DEVRAIT ÊTRE CONNECTÉE À L'UNITÉ D'ALIMENTATION AC ET LA BATTERIE D'URGENCE ET LA LUMIÈRE DE TEST/CHARGE S'ILLUMINE, INDIQUANT QUE LA BATTERIE SE CHARGE.

ESSAIS & ENTRETIEN DE LA BATTERIE:

FAITES UN TEST DE DÉCHARGE À COURT TERME APRÈS AVOIR CHARGÉ LA BATTERIE D'URGENCE AU MINIMUM UNE HEURE. CHARGEZ 24 HEURES AVANT D'EFFECTUER UN TEST DE DÉCHARGE À LONG TERME.

SUIVRE LES DIRECTIVES DU FABRICANT DE BATTERIE / CONDUCTEUR EM (SITE WEB) POUR LES DIRECTIVES PÉRIODIQUES REQUISES EN MATIÈRE DE TEST ET D'ENTRETIEN.