

CYCLE 3800

PROJECT PROJÉT
SPEC TYPE
NOTES

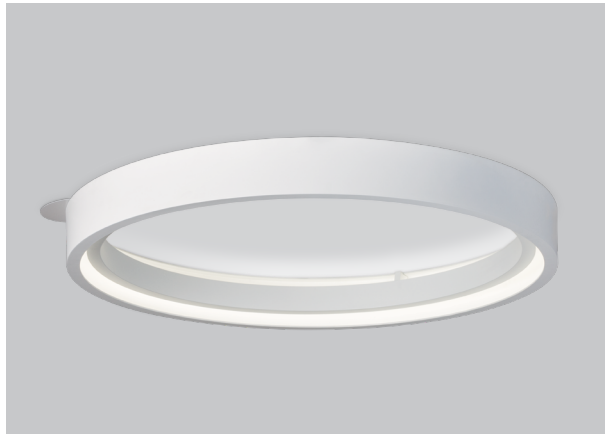

FINISH FINI

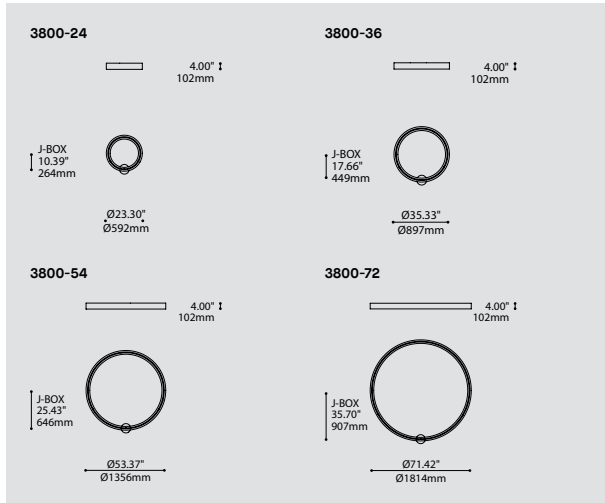
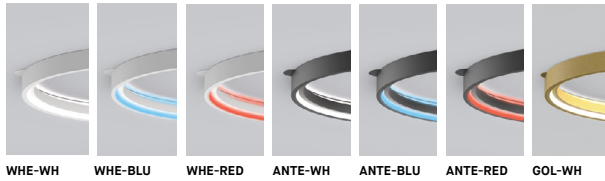

ORDERING SPECIFICATION	SPECIFICATION DE COMMANDE	CODE
MODEL MODÈLE		
3800-24	CYCLE 24"	
3800-36	CYCLE 36"	
3800-54	CYCLE 54"	
3800-72	CYCLE 72"	
LIGHT SOURCE SOURCE LUMINEUSE		
LED	REGULAR OUTPUT	
LED.HO	HIGH OUTPUT	
LED.SHO*	SUPER HIGH OUTPUT	
	* NOT AVAILABLE WITH DP CONTROL OPTION	
COLOR TEMPERATURE TEMPÉRATURE DE COULEUR		
27	2700K	
30	3000K	
35	3500K	
40*	4000K	
	* LONGER LEAD TIME MAY APPLY. PLEASE CONTACT YOUR EUREKA REPRESENTATIVE FOR TUNEABLE WHITE. PLEASE CONTACT YOUR EUREKA REPRESENTATIVE	
COLOR RENDERING INDEX (CRI) INDICE DE RENDU DE COULEUR (IRC)		
90	90+ CRI	90
VOLTAGE VOLTAGE		
120V	120 VOLT	
277V	277 VOLT	
CONTROL OPTION OPTION DE CONTRÔLE		
DV	0-10V DIMMING (120V-277V)	
DP	PHASE DIMMING (120V ONLY)	
NLTAIR2*	NLIGHT AIR CONTROL GEN 2	
NLIGHT*	NLIGHT WIRED CONTROL	
	*NLIGHT INTEGRATION REQUIRES A REMOTE POWER PACK (39NLAA FOR NLTAIR2 OR 39NLWA FOR NLIGHT). *EMERGENCY BATTERY NOT AVAILABLE WITH NLIGHT OPTIONS REFER TO NLIGHT GUIDE AND INSTALLATION SHEET FOR ALL REQUIREMENTS.	
EMERGENCY BATTERY BATTERIE D'URGENCE		
	FOR 120-277V. EM DRIVER BOX INCLUDED, INSTALLED REMOTELY. SEE EM GUIDE FOR DETAILS.	
EMB*	EMERGENCY BATTERY FOR REMOTE BOX	
	* 3981EA ACCESSORY IS REQUIRED	
DRIVER POSITION POSITION DU PILOTE		
RDP*	RECESSED DRIVER	RDP
	* 3981C OR 3981D ACCESSORY IS REQUIRED	
CANOPY FINISH FINI PAVILLON		
WHE	WHITE FINE TEXTURE	
ANTE	ANTHRACITE FINE TEXTURE	
GOL	GOLD	
RING FINISH FINI ANNEAU		
WHE	WHITE FINE TEXTURE	
ANTE	ANTHRACITE FINE TEXTURE	
GOL	GOLD	
RAL*	PLEASE SPECIFY RAL CODE	
	* LONGER LEAD TIME MAY APPLY. PLEASE CONTACT YOUR EUREKA REPRESENTATIVE	
OPTIONAL INSIDE FINISH OF EXTERNAL RING FINI INTERNE OPTIONNEL DE L'ANNEAU EXTÉRIEUR		
BLU	BLUE	
RED	RED	
	IF NO OPTION IS SELECTED, THE INSIDE FINISH OF THE EXTERNAL RING WILL BE WHITE	
ACCESSORY ACCESSOIRE		
3981C	JUNCTION BOX FOR RECESSED DRIVER OPTION (FOR 3800-24, 3800-36 (REG & HO), 3800-54 (REG), 3800-72 (REG))	
3981D	JUNCTION BOX FOR RECESSED DRIVER OPTION (FOR 3800-36 (SHO), 3800-54 (HO & SHO), 3800-72 (HO & SHO))	
39NLAA	NLIGHT AIR GEN 2 REMOTE POWER PACK	
39NLWA	NLIGHT WIRED REMOTE POWER PACK	
EMERGENCY BATTERY ACCESSORY ACCESSOIRE BATTERIE D'URGENCE		
3981EA	ELECTRICAL BOX FOR EMB EMERGENCY BATTERY	

PRODUCT CHARACTERISTICS CARACTÉRISTIQUES DU PRODUIT



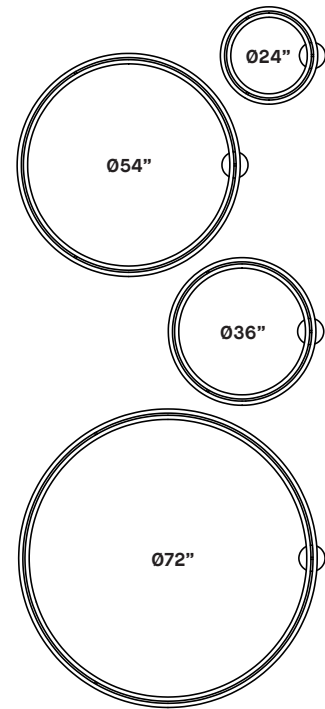
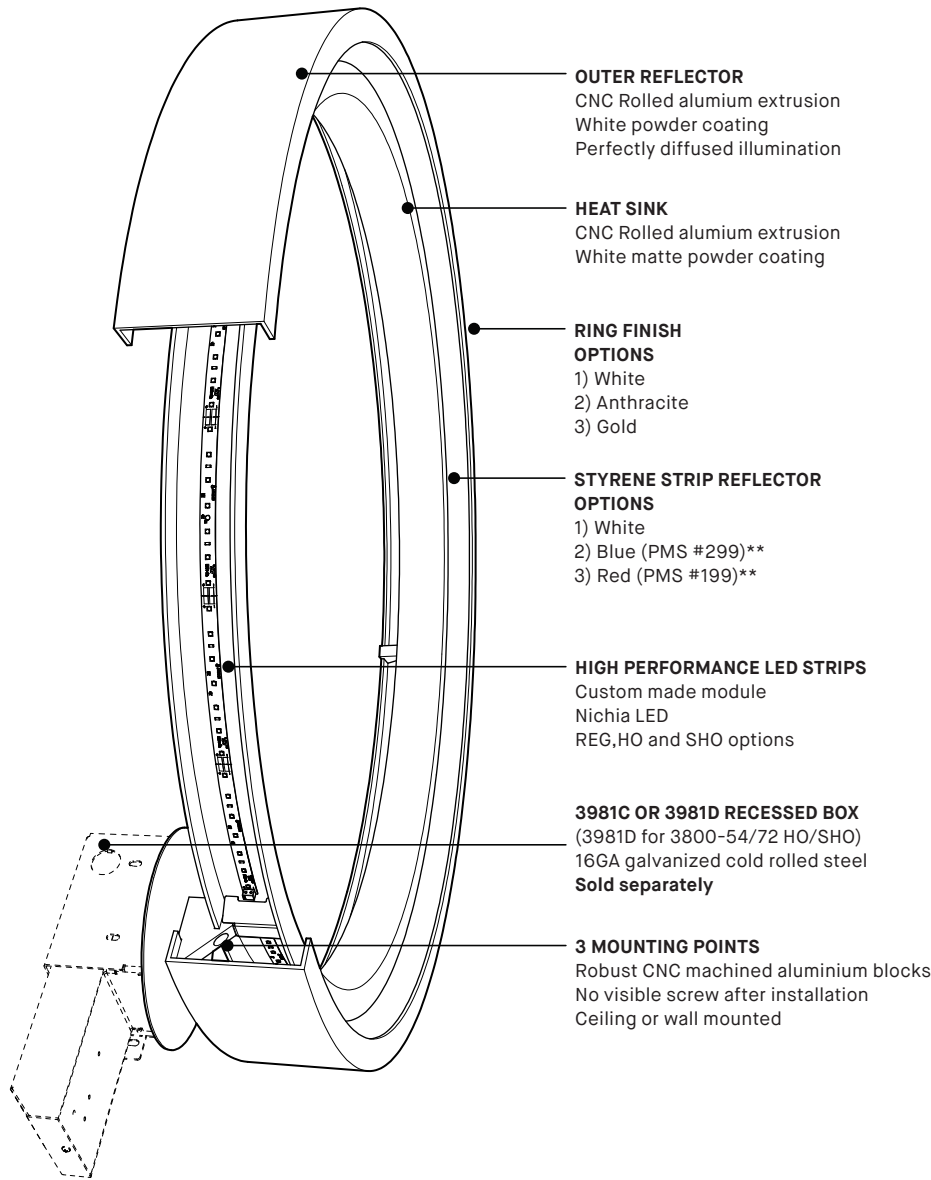

4 VERSATILE SIZES
An infinite number of possible layouts
From the smallest to the largest space

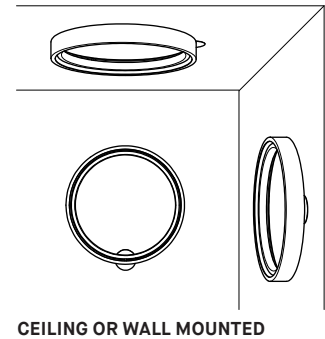

PRODUCT SPECIFICATION

	3800-24 REG/HO/SHO	3800-36 REG/HO/SHO	3800-54 REG/HO/SHO	3800-72 REG/HO/SHO
PERFORMANCE				
SYSTEM WATTAGE	19.2 W / 40.7 W / 62.4 W	30.5 W / 76.8 W / 62.4 W	48.3 W / 108 W / 165.3 W	64.9 W / 128.8 W / 199.9 W
DELIVERED LUMENS (4000K) WHE	1343 / 2722 / 3428	2276 / 5220 / 6586	3663 / 7462 / 10596	5059 / 9924 / 14756
DELIVERED LUMENS (4000K) ANTE OR GOL	961 / 1944 / 2449	1518 / 3478 / 4382	2544 / 5181 / 7371	3611 / 7104 / 10560
OTHER INFORMATIONS				
LUMINAIRE'S WEIGHT	15LBS / 7KG	21LBS / 10KG	33LBS / 15KG	45LBS / 20KG
L70 (LUMEN MAINTENANCE)	> 60 000 HRS	> 60 000 HRS	> 60 000 HRS	> 60 000 HRS

EFFICACY MULTIPLIERS

CRI	CCT	FACTOR
90+	4000K	1.00
90+	3500K	0.96
90+	3000K	0.92
90+	2700K	0.87

LIGHT DISTRIBUTION

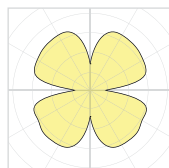

Visit our website for warranty terms and conditions.

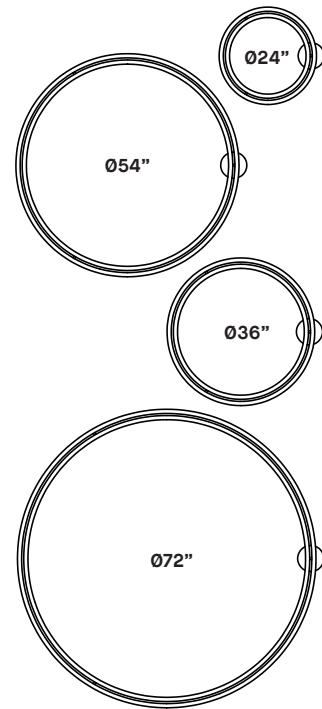
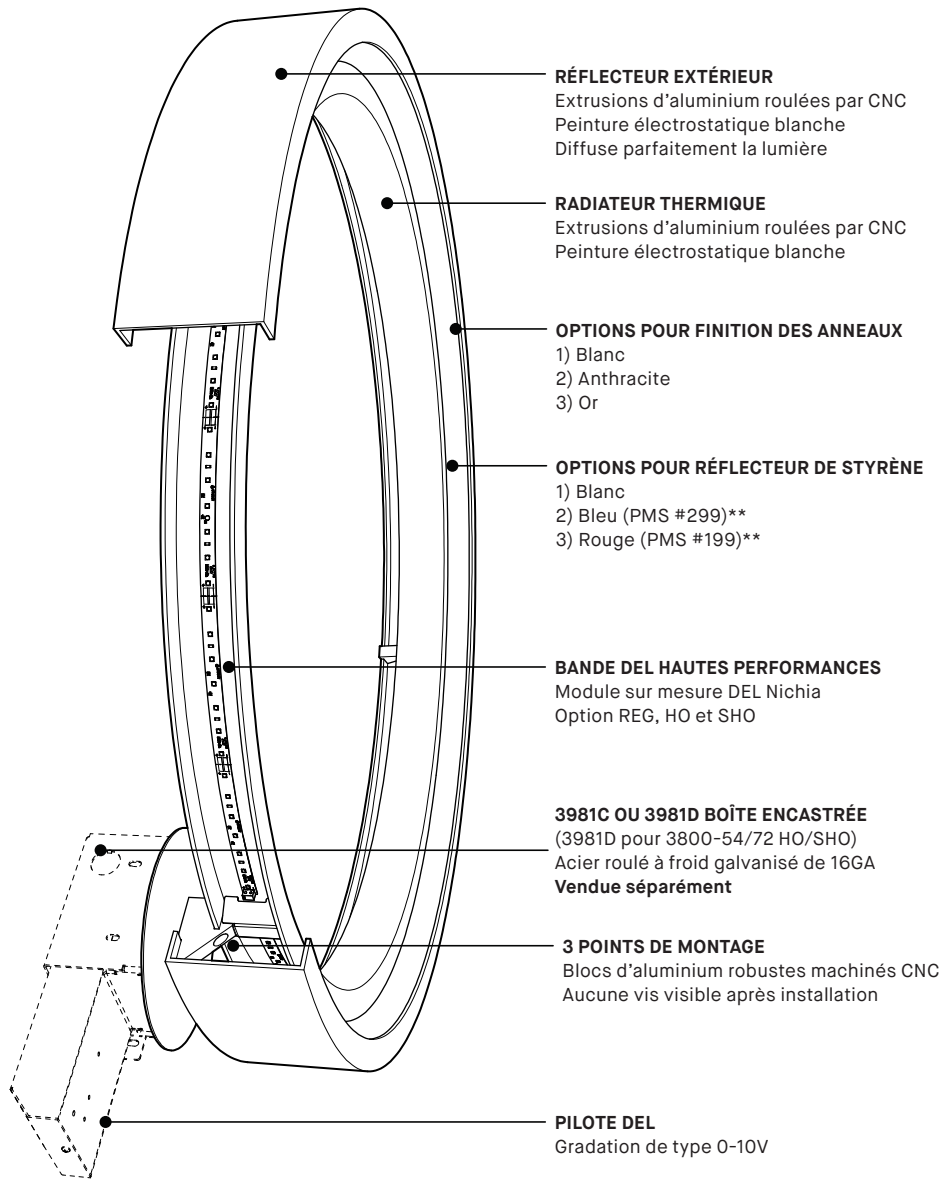

4 FORMATS POLYVALENTS

Une infinité de combinaisons possibles
Pour les petits aux plus grands espaces

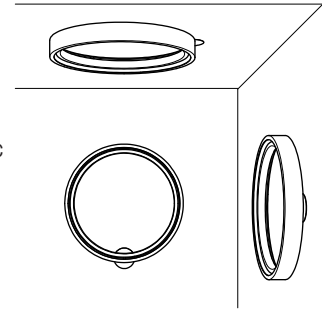

INSTALLATION MURALE OU EN PLAFONNIER

SPÉCIFICATION PRODUIT

3800-24
REG/HO/SHO

3800-36
REG/HO/SHO

3800-54
REG/HO/SHO

3800-72
REG/HO/SHO

PERFORMANCE

PERFORMANCE	3800-24 REG/HO/SHO	3800-36 REG/HO/SHO	3800-54 REG/HO/SHO	3800-72 REG/HO/SHO
PUISSANCE TOTALE	19.2 W / 40.7 W / 62.4 W	30.5 W / 76.8 W / 62.4 W	48.3 W / 108 W / 165.3 W	48.3 W / 108 W / 165.3 W
LUMENS RÉELS (4000K) WHE	1343 / 2722 / 3428	2276 / 5220 / 6586	3663 / 7462 / 10596	5059 / 9924 / 14756
LUMENS RÉELS (4000K) ANTE OU GOL	961 / 1944 / 2449	1518 / 3478 / 4382	2544 / 5181 / 7371	3611 / 7104 / 10560

AUTRES INFORMATIONS

AUTRES INFORMATIONS	3800-24	3800-36	3800-54	3800-72
POIDS	15LBS / 7KG	21LBS / 10KG	33LBS / 15KG	45LBS / 20KG
L70 (MAINTENANCE DE LA LUMIÈRE)	> 60 000 HRS	> 60 000 HRS	> 60 000 HRS	> 60 000 HRS

FACTEUR D'EFFICACITÉ

IRC	CCT	FACTEUR
90+	4000K	1.00
90+	3500K	0.96
90+	3000K	0.92
90+	2700K	0.87

DISTRIBUTION LUMINEUSE

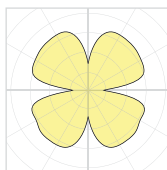

Visitez notre site Web pour les termes et conditions.

JUNCTION BOX 3981E

PROJECT PROJET
SPEC TYPE
NOTES



ORDERING SPECIFICATION SPÉCIFICATION DE COMMANDE CODE

MODEL MODÈLE		
3981EA	APPROX. 10W MAX EMERGENCY BACKUP POWER	
3981EB	APPROX. 5W MAX EMERGENCY BACKUP POWER	

PRODUCT CHARACTERISTICS CARACTÉRISTIQUES DU PRODUIT

- DESIGN:** Remote junction box and cover with an emergency backup driver. Features matching wires and labelling to simplify installation. Is required to complete luminaires ordered with EMB remote emergency box option (selected models, refer to specification sheets. Other models possible upon request). Available in several power outputs, selected according to the luminaire power.
- STRUCTURE:** Die-stamped 16 gauge grey painted steel. Knockouts on all 4 sides from 1/2" to 1-1/4".
- CERTIFIED:** c-CSA-us, UL, RoHS, NEMA Type 1, FCC
- CONCEPTION:** Boîte de jonction à distance avec couvercle avec batterie d'urgence intégré. Contient des fils avec couleurs et étiquetage pour simplifier l'installation. Requis pour compléter un luminaire commandée avec l'option EMB (voir pages de spécification pour produits avec l'option EMB. Autres produits possibles sur demande). Disponible en plusieurs puissances, sélectionnées en fonction du luminaire.
- STRUCTURE:** Acier plié de 16 jauge peinturé gris avec coins soudés. Débouchures sur 4 côtés 1/2" à 1-1/4".
- CERTIFIÉ:** c-CSA-us, UL, RoHS, NEMA Type 1, FCC

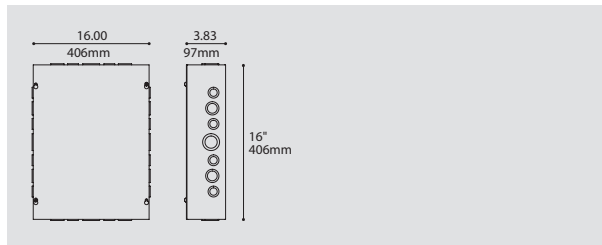

INSTALLATION SUMMARY SOMMAIRE D'INSTALLATION

STEP 1 ÉTAPE 1

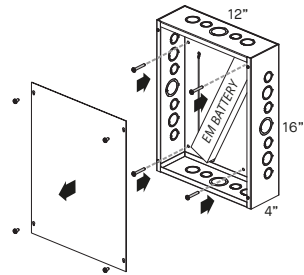

Remove cover and fasten box remotely to a wall or a ceiling.
Enlever le couvercle et fixer la boîte à distance sur un mur ou un plafond.

STEP 2 ÉTAPE 2

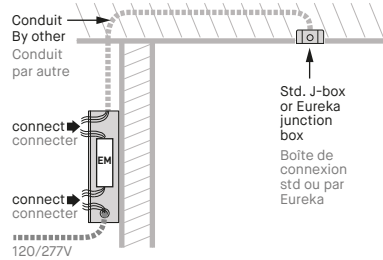

Run conduit from box to junction box of luminaire. Conduit must have a minimum of 5 wires with wire gauge and maximum distance as per EM driver distance chart. Connect EM driver to conduit wires and ac branch circuit. Faites passer le conduit de la boîte EM à la boîte de connexion du luminaire. Consulter le tableau de "distance maximale" disponible dans la feuille d'installation. Branchez la batterie EM avec les fils du conduit ainsi que la ligne 120V ou 277V.

STEP 3 ÉTAPE 3

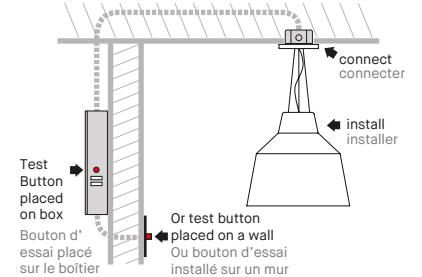

Install luminaire & connect its wires to conduit. Install test button on wall or box (wall plate not supplied). Installer le luminaire & connecter les fils au conduit. Installer le bouton d'essai sur le mur ou boîtier (plaque murale non fournie).

REFER ALSO TO INSTALLATION DRAWING AND EM GUIDE FOR MORE INFORMATION.
CONSULTEZ LE DESSIN D'INSTALLATION ET LE GUIDE EM POUR PLUS D'INFORMATIONS.



SPECIFICATION

3981E REMOTE EMERGENCY BOX KIT - IOTA EM DRIVER

SAFETY GUIDELINES :

- > Follow safety instructions and guidelines of EM battery/driver manufacturer for the specific model.
- > Install by qualified personnel in accordance with the National Electrical Code and local regulations.
- > Turn off power supply before installation or servicing the fixture.

EMB LOCATION :

- > The 3981E box connects to a luminaire ordered with an EMB option (which has specific EM WIRING).
- > Consult our chart for maximum remote distance of EM battery to luminaire leds.
- > Establish desired location for EMB box & EM test button on box or on a wall.

EM Remote Distance Chart
Maximum distance EM battery to Luminaire LEDs (Ft)

MAX EM BOX DISTANCE (Ft)	CONDUIT WIRE GAUGE (AWG)							
	10	12	14	16	18	20	22	
LUMINAIRE	200mA	1043'	651'	413'	259'	163'	103'	65'
DRIVER	350mA	596'	372'	236'	148'	93'	59'	37'
OUTPUT	500mA	417'	261'	165'	104'	65'	41'	26'
CURRENT*	700mA	298'	186'	118'	74'	47'	29'	18'
(Amps)	1000mA	209'	130'	83'	52'	33'	21'	13'
*Contact Eureka	1400mA	149'	93'	59'	37'	23'	15'	9'
	2000mA	104'	65'	41'	26'	16'	10'	6'
	3000mA	70'	43'	28'	17'	11'	7'	4'

EMB PLACEMENT EXAMPLES :

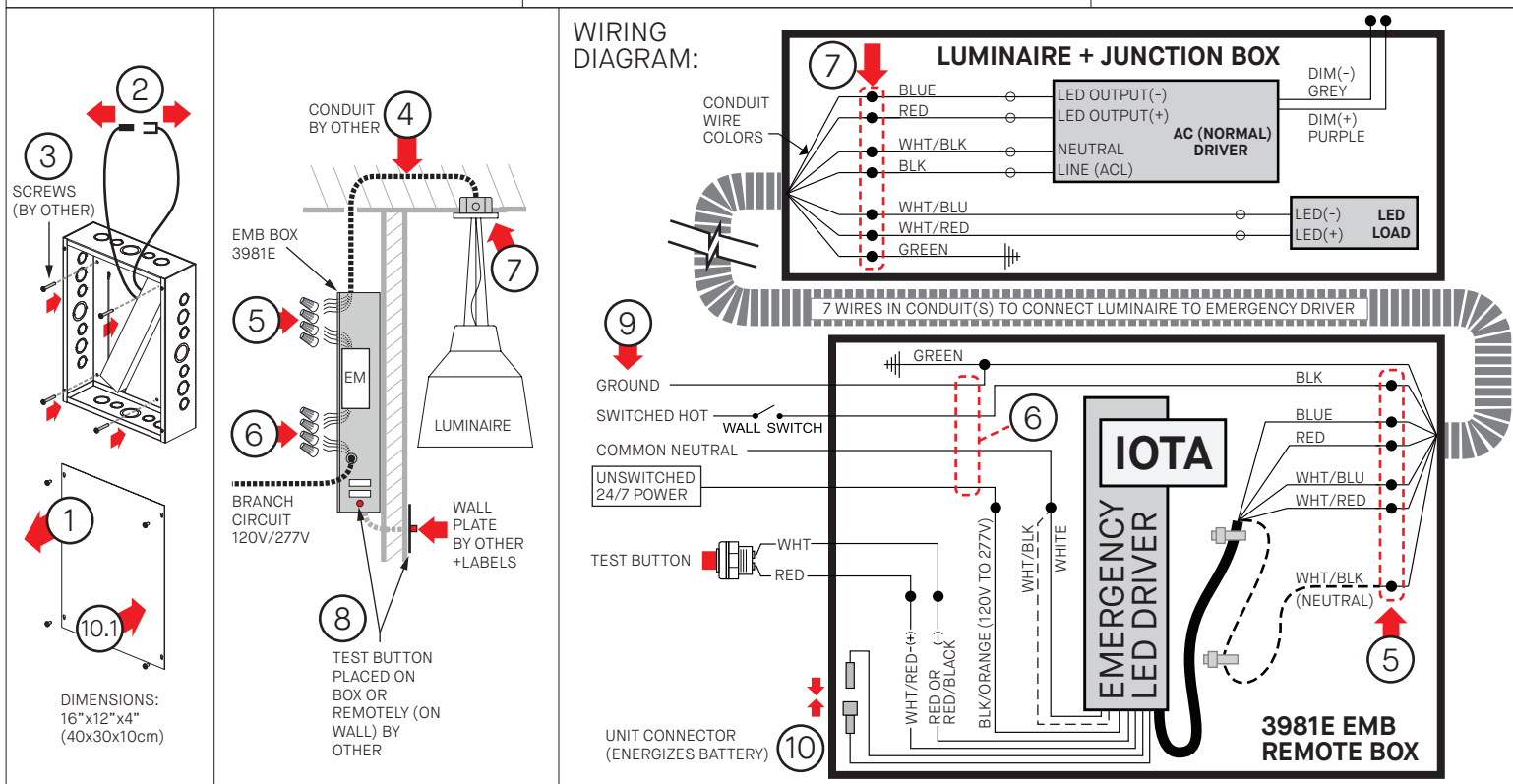
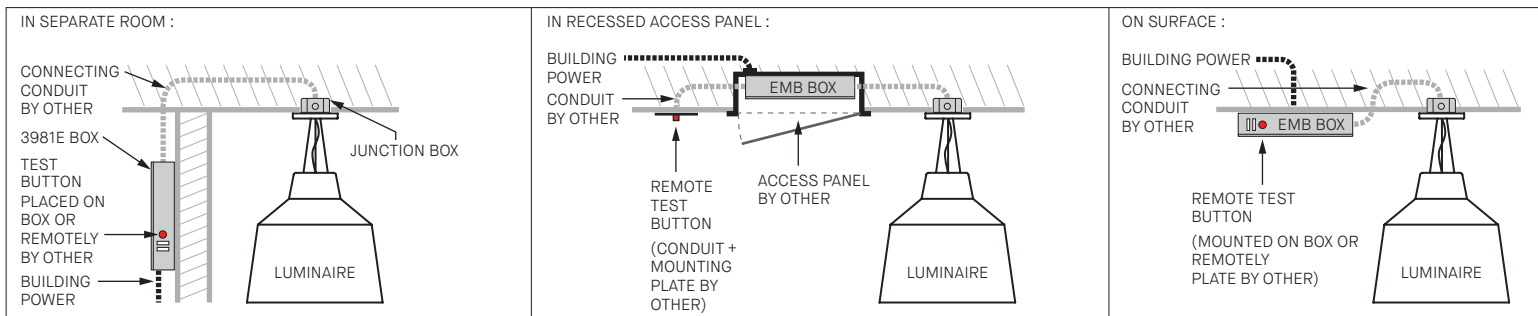

INSTALLATION

- 1 - REMOVE BOX COVER.
- 2 - IF CONNECTED, DISCONNECT THE EM BATTERY 'UNIT CONNECTOR' (WHITE).
- 3 - SCREW BOX TO MOUNTING SURFACE (SCREWS NOT SUPPLIED)
- 4 - RUN CONDUIT FROM EMB BOX TO ELECTRICAL JUNCTION BOX OF LUMINAIRE. CONDUIT MUST HAVE MIN. 7 WIRES AND WIRE GAUGE AS PER DISTANCE CHART.
- 5 - CONNECT CONDUIT WIRES TO EM BATTERY AS PER WIRING DIAGRAM.
CAREFULLY NOTE WHICH WIRE COLORS ARE CONNECTED TOGETHER ON EACH END.
- 6 - CONNECT BATTERY TO AC BRANCH CIRCUIT : GROUND, NEUTRAL, 24/7 UNSWITCHED LINE (HOT) AND SWITCHED LINE (ON SAME CIRCUIT AS LUMINAIRE ON/OFF CONTROL).
- 7 - INSTALL SPECIFIC EM LUMINAIRE, CONNECT WIRES TO CONDUIT USING THE SAME CORRESPONDING COLORS NOTED AT THE EM BATTERY-CONDUIT CONNECTION.
- 8 - INSTALL EM BATTERY TEST BUTTON IN DESIRED LOCATION. WALL PLATE BY OTHER. ADD LABELS "PUSH TO TEST" & CHARGING INDICATOR LIGHT".
- 9 - SWITCH ON AC POWER.
- 10 - JOIN THE EM BATTERY CONVERTOR CONNECTOR. 10.1 - INSTALL BOX COVER.
- 11 - IF EMB IS FAR FROM THE LUMINAIRE, IDENTIFY TO WHICH LUMINAIRE IT IS CONNECTED.

AT THIS POINT POWER SHOULD BE CONNECTED TO BOTH THE AC DRIVER AND THE EMERGENCY DRIVER & TEST/CHARGE LIGHT SHOULD ILLUMINATE, INDICATING BATTERY IS CHARGING.

TESTING & EM DRIVER/BATTERY MAINTENANCE:

CONDUCT A SHORT-TERM DISCHARGE TEST AFTER THE EMERGENCY DRIVER HAS BEEN CHARGED FOR MINIMUM ONE HOUR. CHARGE FOR 24 HOURS BEFORE CONDUCTING A LONG-TERM DISCHARGE TEST.

FOLLOW GUIDELINES FROM THE EM DRIVER/BATTERY MANUFACTURER INSTRUCTIONS FOR THE REQUIRED PERIODIC TESTING AND MAINTENANCE GUIDELINES.

3981E BOÎTE D'URGENCE À DISTANCE - DRIVER EM IOTA

DIRECTIVES DE SÉCURITÉ:

- > Suivre les consignes de sécurité et les directives d'installation du fabricant de la batterie d'urgence.
- > Installer par du personnel qualifié conformément au code électrique national et local.
- > Fermer l'alimentation avant l'installation ou l'entretien.

EMPLACEMENT :

- > Cette boîte 3981E se connecte à un luminaire commandé avec l'option EMB (qui a du filage spécifique).
- > Consulter le tableau pour la distance maximale de la batterie d'urgence aux DELs du luminaire.
- > Déterminer l'emplacement souhaité pour la boîte EMB et le bouton de test d'urgence.

EXEMPLES D'EMPLACEMENT:

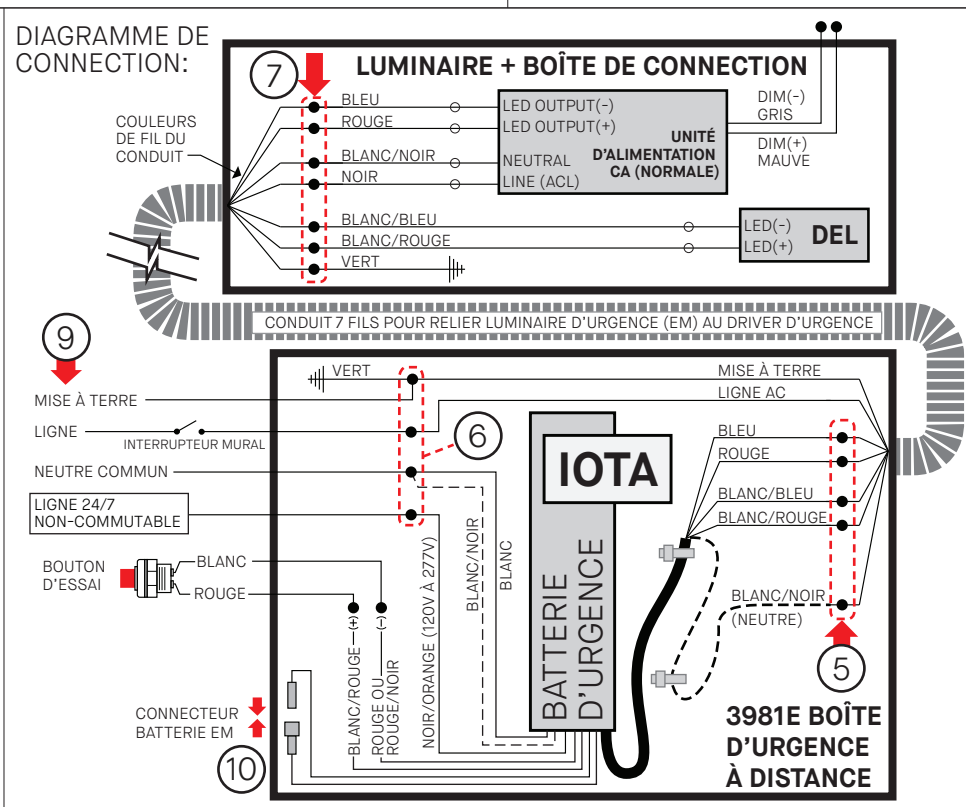
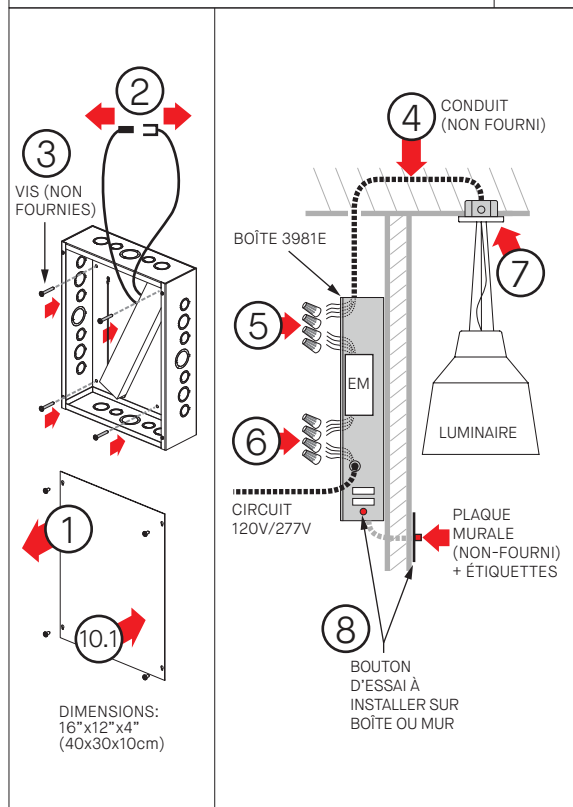
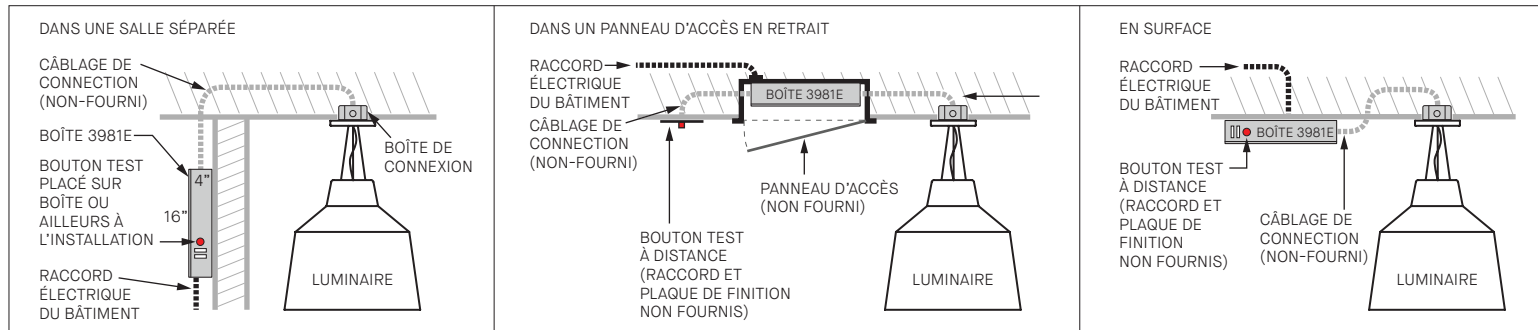

Charte de distance d'installation EM
Distance maximale entre Batterie d'urgence et DELs du luminaire (Pi)

DISTANCE MAX D'INSTALLATION (Pi)	GAUGE DE FILS DU CONDUIT (AWG)							
	10	12	14	16	18	20	22	
COURANT	200mA	1043'	651'	413'	259'	163'	103'	65'
ALIMENTATION DU LUMINAIRE*	350mA	596'	372'	236'	148'	93'	59'	37'
(Amp)	500mA	417'	261'	165'	104'	65'	41'	26'
*Contacter Eureka	700mA	298'	186'	118'	74'	47'	29'	18'
	1000mA	209'	130'	83'	52'	33'	21'	13'
	1400mA	149'	93'	59'	37'	23'	15'	9'
	2000mA	104'	65'	41'	26'	16'	10'	6'
	3000mA	70'	43'	28'	17'	11'	7'	4'

INSTALLATION

- 1 - DÉVISSER LE COUVERCLE.
- 2 - DÉCONNECTER LE CONNECTEUR BLANC DE BATTERIE EM (UNIT CONNECTOR).
- 3 - FIXER LA BOÎTE SUR LE MUR/PALAFOND AVEC VIS (NON FOURNIES)
- 4 - PASSER DU CONDUIT DU EMB VERS LA BOÎTE DE CONNEXION ÉLECTRIQUE DE LUMINAIRE. LE CONDUIT DOIT AVOIR 7 FILS AVEC GAUGE DE FIL SELON CHARTRE DE DISTANCE.
- 5 - CONNECTER LES FILS DE CONDUIT À LA BATTERIE EM SELON LE SCHÉMA DE CÂBLAGE.
- 6 - CONNECTER LA BATTERIE AU CIRCUIT DE DÉRIVATION AC (FILS: MISE A LA TERRE, NEUTRE, LIGNE & LIGNE SANS INTERRUPTEUR 24H/7* (*DOIT ETRE LE MEME CIRCUIT QUE LE CONTROLE DU LUMINAIRE)).
- 7 - INSTALLER LUMINAIRE SPÉCIFIQUE EM, CONNECTER LES FILS AU CONDUIT AVEC MÊMES COULEURS CORRESPONDANTES DE LA BATTERIE EM AUX FILS DE CONDUIT.
- 8 - INSTALLEZ LE BOUTON D'ESSAI DE BATTERIE EM DANS L'ENDROIT SOUHAITÉ (PLAQUE MURALE PAR AUTRE). COLLER ÉTIQUETTES "PUSH TO TEST" & CHARGING INDICATOR LIGHT".

- 9 - ALIMENTER LE CIRCUIT AC.
- 10 - JOINDRE CONNECTEUR BLANC DE BATTERIE EM. 10.1 - INSTALLER COUVERCLE DE BOITE.
- 11 - SI LE EMB EST LOIN DU LUMINAIRE, IDENTIFIER À QUEL LUMINAIRE IL EST CONNECTÉ.

A CE STADE, L'ALIMENTATION DEVRAIT ÊTRE CONNECTÉE À L'UNITÉ D'ALIMENTATION AC ET LA BATTERIE D'URGENCE ET LA LUMIÈRE DE TEST/CHARGE S'ILLUMINE, INDIQUANT QUE LA BATTERIE SE CHARGE.

ESSAIS & ENTRETIEN DE LA BATTERIE:

FAITES UN TEST DE DÉCHARGE À COURT TERME APRÈS AVOIR CHARGÉ LA BATTERIE D'URGENCE AU MINIMUM UNE HEURE. CHARGEZ 24 HEURES AVANT D'EFFECTUER UN TEST DE DÉCHARGE À LONG TERME.

SUIVRE LES DIRECTIVES DU FABRICANT DE BATTERIE / CONDUCTEUR EM (SITE WEB) POUR LES DIRECTIVES PÉRIODIQUES REQUISES EN MATIÈRE DE TEST ET D'ENTRETIEN.