

# MOONRISE CLASSIC 3530-23

QUICKSHIP

PROJECT PROJET

SPEC TYPE

NOTES

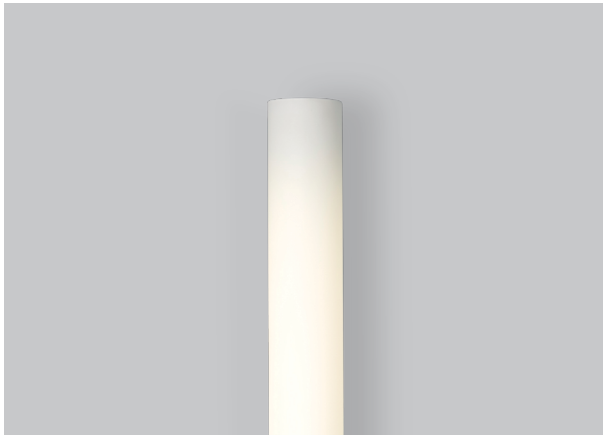

3530-23

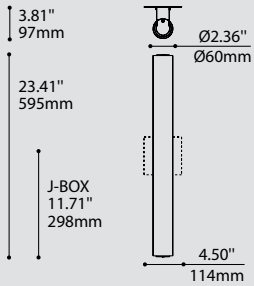

## ORDERING SPECIFICATION SPÉCIFICATION DE COMMANDE

CODE

### QUICKSHIP

QS5 QUICKSHIP 5 DAYS - MAXIMUM 5 UNITS QUICKSHIP 5 JOURS - MAXIMUM 5 UNITÉS  
 QS10 QUICKSHIP 10 DAYS - MAXIMUM 20 UNITS QUICKSHIP 10 JOURS - MAXIMUM 20 UNITÉS

### MODEL MODÈLE

3530-23 MOONRISE CLASSIC 23" (ROUND GLASS)

3530-23

### LIGHT SOURCE SOURCE LUMINEUSE

LED REGULAR OUTPUT  
 LED.HO HIGH OUTPUT

### COLOR TEMPERATURE TEMPÉRATURE DE COULEUR (A)

30 3000K  
 35 3500K  
 40 4000K

### VOLTAGE VOLTAGE

120V 120 VOLT  
 277V 277 VOLT

### DIMMING OPTION OPTION DE GRADATION

DV 0-10V DIMMING (120V-277V)

### HOUSING & END CAPS FINISH FINI BOITIER & EMBOUTS\*

END CAPS ALWAYS THE SAME FINISH AS THE HOUSING.

CHR CHROME  
 SC SATIN CHROME

### DIFFUSER FINISH FINI DIFFUSEUR

WH WHITE

WH

### ACCESSORY ACCESSOIRE

3980 MINI JUNCTION BOX

## PRODUCT CHARACTERISTICS CARACTÉRISTIQUES DU PRODUIT



**DESIGN:** Modern classic round profile wall sconce or surface mounted fixture. ADA compliant.

**HOUSING & END CAPS:** Machined steel end caps & die-stamped steel structure with plated finish.

**DIFFUSER:** Hand blown white triplex glass.

**CERTIFIED:** c-CSA-us

**CONCEPTION:** Applique ou plafonnier cylindrique classique et contemporain. Conforme à la norme ADA.

**BOITIER & EMBOUTS:** Embout d'acier usiné et acier embouti plaqués.

**ABAT-JOUR:** Verre triplex blanc soufflé à la main.

**CERTIFIÉ:** c-CSA-us

# MOONRISE CLASSIC, MOONSET CLASSIC 353X - 23

3530-23 MOONRISE    3531-23 MOONSET

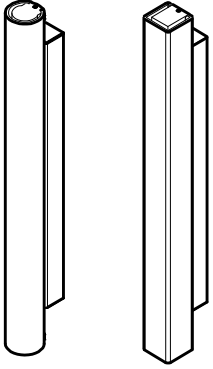

**DIFFUSER**  
Hand blown white triplex glass

**ENDCAPS**  
Machined steel endcaps mechanically attached to structure with one-way security screw

**EASY MOUNTING**  
Die-formed steel structure provides an easy access to component wiring

**LED LIGHT ENGINE**  
ANSI binned white LED Nichia w/ on-board thermal management

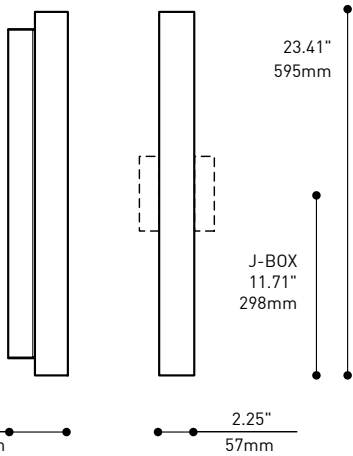

**PRODUCT SPECIFICATION**    **3530-23 REG**    **3530-23 HO**    **3531-23 REG**    **3531-23 HO**

PERFORMANCE				
SYSTEM WATTAGE	10 W	14.5 W	10 W	14.5 W
DELIVERED LUMENS (4000K)	899 LM	1292 LM	889 LM	1278 LM
EFFICACY	89.9 LM/W	89.1 LM/W	89.9 LM/W	88.14 LM/W

OTHER INFORMATIONS				
LUMINAIRE'S WEIGHT	6.13 LBS / 2.78 KG	6.13 LBS / 2.78 KG	6.13 LBS / 2.78 KG	6.13 LBS / 2.78 KG
L70 (MAINTENANCE DE LA LUMIÈRE)	> 60 000 HRS	> 60 000 HRS	> 60 000 HRS	> 60 000 HRS

**EFFICACY MULTIPLIERS**

CRI	CCT	FACTOR
80+	4000K	1.00
80+	3500K	0.98
80+	3000K	0.94
80+	2700K	0.91
90+	4000K	0.88
90+	3500K	0.85
90+	3000K	0.81
90+	2700K	0.77

**LIGHT DISTRIBUTION**

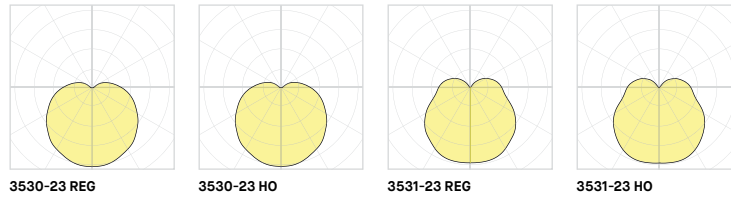

**TECHNICAL DATA**

# MOONRISE CLASSIC, MOONSET CLASSIC 353X - 23

3530-23  
MOONRISE

3531-23  
MOONSET

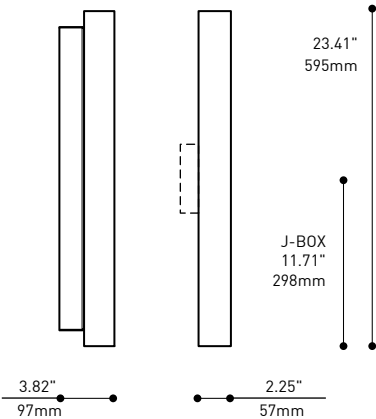
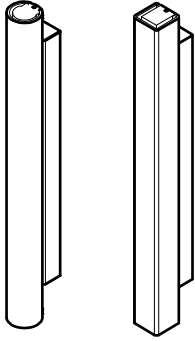

**DIFFUSEUR**  
Verre triplex blanc soufflé à la main

**EMBOUS**  
Usinés en acier  
attachés mécaniquement à la structure  
à l'aide d'une vis de sécurité

**INSTALLATION SIMPLE**  
Système de montage facilitant  
l'accès aux composants électriques

**SOURCE LUMINEUSE À LED**  
Bandes de LED Nichia blanche  
à alimentation 12V offertes  
avec dissipateur thermique intégré

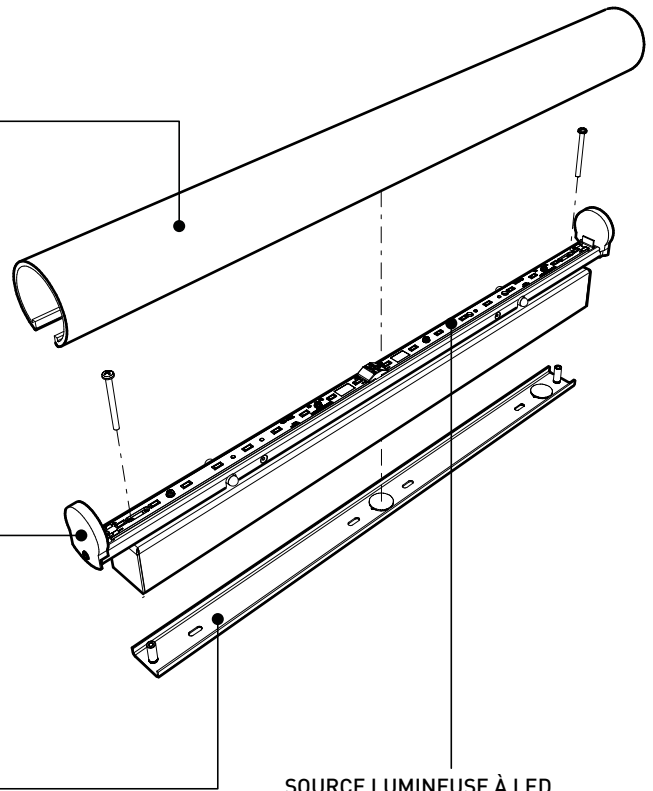

SPECIFICATION PRODUIT	3530-23 REG	3530-23 HO	3531-23 REG	3531-23 HO
-----------------------	-------------	------------	-------------	------------

PERFORMANCE				
PUISSANCE TOTALE	10 W	14.5 W	10 W	14.5 W
LUMENS RÉELS (4000K)	899 LM	1292 LM	889 LM	1278 LM
EFFICACITÉ	89.9 LM/W	89.1 LM/W	89.9 LM/W	88.14 LM/W
AUTRES INFORMATIONS				
POIDS PAR TÊTE	6.13 LBS / 2.78 KG	6.13 LBS / 2.78 KG	6.13 LBS / 2.78 KG	6.13 LBS / 2.78 KG
L70 (MAINTENANCE DE LA LUMIÈRE)	> 60 000 H	> 60 000 H	> 60 000 H	> 60 000 H

**FACTEUR D'EFFICACITÉ**

IRC	CCT	FACTEUR
80+	4000K	1.00
80+	3500K	0.98
80+	3000K	0.94
80+	2700K	0.91
90+	4000K	0.88
90+	3500K	0.85
90+	3000K	0.81
90+	2700K	0.77

**DISTRIBUTION LUMINEUSE**

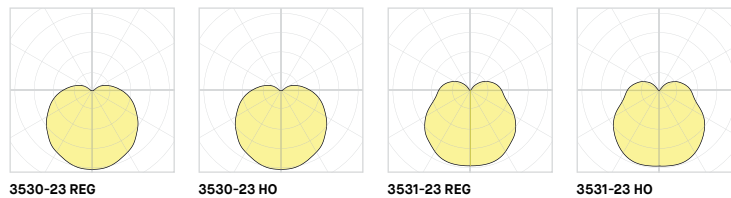

Visitez notre site Web pour les termes et conditions.



## DONNÉES TECHNIQUES